

LUMINAIRES

TRADITIONAL LIGHTING

Lan 1000

LUMINAIRE STYLE CODE LN10

Base Dimensions & template

HT	Height	39 3/16"
WT	Width	17 13/16"

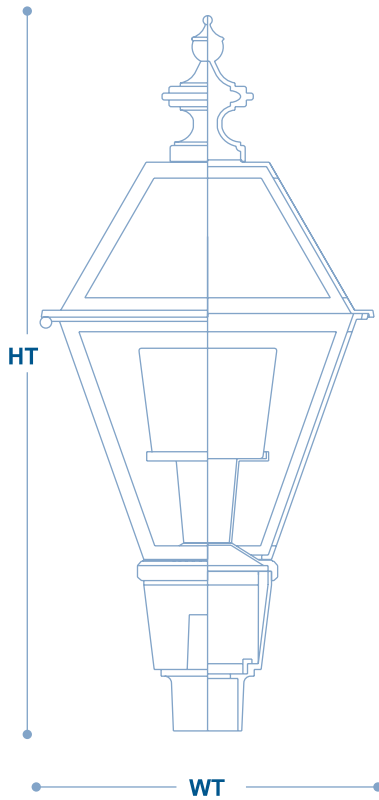

LUMINAIRE SPECIFICATION

Luminaire housing shall be made of ASTM 356.2 aluminum, cast in permanent molds and shall encompass the following specifications:

The upper chamber or lid, shall be topped by a decorative cast aluminum finial and connected to the optical chamber or cage by means of a hinge system and locking mechanism for quick and easy lamp service.

The optical chamber or cage, shall accommodate a glass borosilicate refractor or an aluminum multifaceted reflector. The enclosure shall be formed by polycarbonate, acrylic, tempered or borosilicate lenses mechanically fastened and sealed for weather tight operation.

The electrical chamber or base-fitter shall be a cast aluminum, decorative component designed to accommodate the ballast assembly and shall mount to a post top or bracket by means of a 3" O.D. slip fitter hub and secured by three stainless steel set screws.

The electrical assembly shall be a high power factor ballast, designed to operate an HID lamp up to 400 watts (by others) and shall be integrally mounted to a removable aluminum tray with brackets and fasteners. The lamp holder shall be impact resistant, porcelain glazed and pulse rated 600V-4KV for medium and mogul based lamps.

All assembly fasteners and hardware are rust proof stainless steel and tamperproof.

Shown With
Biloxi
Base

