

Lan 1200

LUMINAIRE STYLE CODE LN12

Base Dimensions & template

HT	Height	30 1/8"
WT	Width	14 1/8"

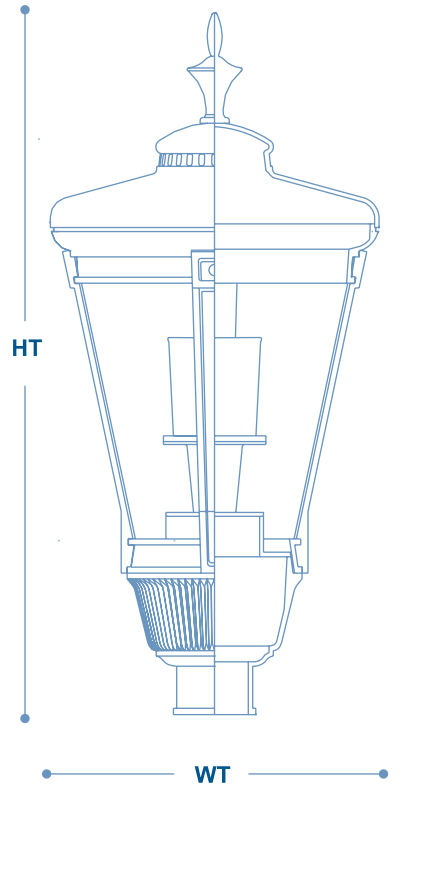

LUMINAIRE SPECIFICATION

The Luminaire Housing shall be made of ASTM 356.2 aluminum, cast in permanent mold.

1. The Lid section of the housing shall be topped by a decorative cast aluminum dome and finial, connected to the middle chamber by means of a locking mechanism for easy and quick lamp service.
2. The cage / optical chamber shall accommodate a specular aluminum reflector for type IV light diffusion. The enclosure shall be formed by a thermo formed clear acrylic lenses, mechanically fastened and sealed.
3. The lower section shall be a cast aluminum decorative base fitter designed to accommodate the ballast assembly and is mounted to a post top by means of a built in 3 1/8" ID slip fitter hub and secured by three stainless steel set screws.

The Electrical Assembly shall be a high power factor ballast up to 250 watt HID lamp, shall be integrally mounted to a removable aluminum tray with non-ferrous brackets and fasteners and may be equipped with a quick-disconnect, optionally fused and thermo-protected. The Lamp holder shall be a medium or mogul base; high impact resistant, porcelain glazed and pulse rated 600 V 4KV for mogul base.

The luminaire and optical chamber are sealed and gasketed for weather tight operation. All assembly fasteners and hardware are rust proof stainless steel and tamperproof. Finish is an electrostatic applied, thermo set polyester powder coating, and UV stabilized. All electrical components and lighting fixture shall be UL and/ or ETL listed, suitable for wet location.

Shown With
Santa Fe
Base